



Description

Deluge Valve is known as a system control valve in a deluge system, used for fast application of water in a spray system. Deluge valve protects areas such as power transformer installation, storage tank, conveyor protection and other industrial application etc. With the addition of foaming agent deluge valve can be used to protect aircraft hanger and inflammable liquid fire.

Technical Specification

Model	A
Nominal size	200, 150, 100, 80 & 50nb
Maximum service Pressure	12 bar (175 psi)
Threaded opening	BSPT
Mounting	90° pattern inlet to outlet Vertical mounting
Factory Hydrostatic Test pressure	25 Kg./sq.cm. (350 PSI)
Flange Connection	ANSI B 16.1 FF # 125 (Flange drilling matching to ANSI B 16.5 # 150)
Trim	Galvanized Steel with Brass Valves
Wet pilot sprinkler height limitation	As per graph in the catalogue
Net weight without trim	200NB - 214 Kg 150NB - 131 Kg 100NB - 77 Kg 80NB - 50 Kg 50NB - 47 Kg
Finish	Red RAL 3001
Approval	UL Listed
Ordering information	Specify: 1) Size of valve 2) Trim type - Dry Pilot Wet Pilot Electric Release Test & Alarm

Valve Operation

Deluge valve is a quick release, hydraulically operated diaphragm valve. It has three chambers, isolated from each other by the diaphragm operated clapper and seat seal. While in 'SET' position, water pressure is transmitted through an external bypass check valve and restriction orifice from the system supply side to the top chamber, so that supply pressure in the top chamber acts across the diaphragm operated clapper which holds the seat against the inlet supply pressure because of differential pressure design.

On detection of fire the top chamber is vented to atmosphere through the outlet port via opened actuation device(s). The top chamber pressure cannot be replenished through the restricted inlet port, thus it reaches less than half the supply pressure instantaneously and the upward force of the supply pressure lifts the clapper allowing water to enter the system piping network and alarm devices.

Trim Description

a) BASIC TRIM

The basic trim is required on deluge valve regardless of the release system. It contain those components which are required in all types of installation, such as the main drain valve, priming connection, drip check valve, emergency release valve and pressure gauges.

b) DRY PILOT TRIM (PNEUMATIC RELEASE)

Dry pilot operation uses a pilot line of closed Sprinklers / QB detectors containing air under pressure, located in the area to be protected. It requires regulated dry air supply with main supply point through restricted orifice.

The pilot line is connected directly to the top of POSITIVE DRAIN ACTUATOR (PDA). The bottom of PDA is connected to the top chamber of the deluge valve.

When the air pressure drops, due to release of any of the release devices on detection of fire, the diaphragm of PDA is lifted and allows the water to drain. This reduces the water pressure in the top chamber of the deluge valve and when the pressure in the top chamber reaches 50% of the supply pressure, the deluge valve opens.

The direct drain of PDA start when the top chamber pressure of deluge valve reaches approximately 0.7 Kg/sq.cm. This positive drain will not permit the deluge valve to close unless the PDA is set manually. The recommended air supply pressure is as per TABLE-1.

LINE WATER PRESSURE Kg./ Sq.cm. MAXIMUM	AIR PRESSURE IN DETECTION LINE Kg./ Sq.cm.	
	MINIMUM	MAXIMUM
2	1.2	3.0
4	1.5	3.0
6	2.0	3.5
8	2.5	3.5
10	3.0	3.5
12	3.5	4.0

Table 1

Wiring Details

c) WET PILOT TRIM (HYDRAULIC RELEASE)

Wet pilot operation uses a pilot line of closed sprinklers containing pressurised water, supplied through the upstream side of the deluge valve, through a restricted orifice. All the release lines are connected to a common release line. Due to release of any one of the release devices, the water pressure in the top chamber of the deluge valve reaches 50% of the supply pressure, the deluge valve opens.

Caution

While using a deluge valve in the wet pilot system the height and the length of the wet pilot detection line is to be limited as given in the wet pilot sprinkler height limitation graph.

d) ELECTRIC RELEASE TRIM

To actuate a deluge valve electrically, a solenoid valve is provided to drain the water from the top chamber of the deluge valve. A pressure switch is provided to activate an electric alarm, to shut down the desired equipment or to give "Tripped" indication to the panel. In addition to this two nos of pressure switches can be used to monitor "Low air pressure" and "Fire condition" when used in dry pilot air line.

e) TEST AND ALARM TRIM WITH SPRINKLER ALARM

This trim is supplied with the sprinkler alarm bell, which bells on actuation of the deluge valve. A test valve is provided to test the normal operation of the sprinkler alarm bell.

Note: Trim without Test and Alarm trim, without Drain & drip valve can be supplied for which please contact marketing.

Resetting Procedure For

- (i) Close the upstream side stop valve provide below the deluge valve.
- (ii) Open both the drain valves and close them when the flow of water has ceased.
- (iii) Inspect and release if required, or close the section of the detection system subjected to "Fire condition".
- (iv) In case of dry pilot detection system, open the air supply valve to build-up air pressure as shown in TABLE-1. Open the priming valve fully and press hold the knob of PDA till the water pressure gauge indicate full service line pressure, then release the PDA knob. Open the upstream side of the stop valve provided below the deluge valve. No water should flow into the system, this can be checked by depressing the drip check valve knob.

Caution

- a. Do not close the priming valve, down stream and upstream stop valves, while the system is in service.
- b. The releasing device must be maintained in the open position, when actuated, to prevent the deluge valve from closure.
- c. While using a Deluge valve in the wet pilot system the height & the length of the wet pilot detection line is to be limited as

shown in the wet pilot sprinkler limitation graph.

- d. Do not connect the Sprinkler Alarm outlet drainline to close a common drain as it may create back pressure and Sprinkler Alarm may not function.
- e. Deluge valve must have support to absorb sudden opening or closing vibration shock to the piping.
- f. The responsibility of maintenance of the protection system and devices in proper operating condition lies with the owner of the system.
- g. Deluge Valve & its trim shall be maintained at a minimum temperature of 4°C, Heat tracing is not permitted.
- h. Deluge Valve must be used in pressurised system

System Testing Procedure

- (i) Keep the upstream side of the stop valve partially open. Open the upstream side of the drain valve, to maintain a minimum pressure of 3 Kg./sq. cm on the upstream side of the deluge valve. To avoid water damage close the system side stop valve. This valve is to be kept in open position after the testing is completed.
- (ii) Open the system side drain valve of the deluge valve.
- (iii) Let any of the release devices to trip. This will result in a sudden drop of water pressure in the deluge valve top chamber resulting the deluge valve to open. The water flowing through the down stream side drain valve confirms that the deluge valve has actuated, immediately close the upstream side stop valve.
- (iv) Once testing is over reset the valve as per procedure given under heading "RESETTING PROCEDURE FOR THE DELUGE VALVE".

Inspection & Maintenance

All the newly installed system piping network must be flushed properly before placing the deluge valve in service. A qualified and trained person must commission the system. After few initial successful tests an authorised person must be trained to perform inspection and testing of the system. It is recommended to have regular inspection and test run the system as per NFPA guidelines or in accordance with the guideline laid down by the organisation having local jurisdiction.

(i) WARNING

Inspection and testing is to be carried out only by authorised and trained personnel. DO NOT TURN OFF the water supply or close any valve to make repair(s) or test the valve, without placing a roving fire patrol in the area protected by the system. Also inform the local security personnel and central alarm station, so that a false alarm is not signalled. It is recommended to carry out physical inspection of the system at least twice in a week.

The inspection should verify that all the control valves are in proper position as per the system requirement and no damage has taken place to any component.

(ii) NORMAL CONDITION

- (a) All main valves are open and are sealed with tamper proof seal.
- (b) Drain valves must be kept closed.
- (c) No leak or drip is detected from the drip valve.
- (d) All the gauges except the system side water pressure gauge, should show the required pressure.
- (e) There should be no leakage in the system.

(iii) NORMAL CONDITION TEST

- (a) The system should be checked for normal condition at least once a month.
- (b) Test the sprinkler alarm bell or electric alarm by turning the alarm test valve to the test position. The alarm should sound. This test should be carried out at least once in a week.
- (c) Depress the drip valve knob. Significant water accumulation indicates a possible seat leakage.
- (d) Conduct the water flow test as per the procedure of system testing at least once in a month.

(iv) PERIODIC CHECK

Conduct the water flow test by actuating few of the release devices provided in the system. Clean all strainer(s) and priming line restriction. This test is to be carried out at least once in six months.

Abnormal Condition

(i) ALARM FAILS TO SOUND

- (a) Check for any obstruction in the alarm test line, Ensure that the sprinkler alarm is freely operating.
- (b) If an electric alarm is provided, check the electrical circuitry to the alarm.

(ii) FALSE TRIPS

- (a) Check for clogging in priming line, restriction orifice check valve, priming valve & strainer.
- (b) Leakage in the release system.
- (c) The deluge air panel orifice clogged or low supply pressure.

(iii) LEAKAGE THROUGH THE DELUGE VALVE

- (a) Damaged deluge valve seat or obstruction on the seat face by foreign object.
- (b) Leakage in release system.
- (c) Partly clogged priming line, restriction check valve.
- (d) Low air pressure on system line or leakage in release system.
- (e) PDA seat leakage due to seat damage or obstruction on seat face by foreign objects (in dry pilot system only)

Notes

- (1) UL Listing is valid only when Deluge Valve is installed with trim set as per trim drawing.
- (2) The trip time of deluge valve on of device through detection network, will depend on volume of detection network. If the trip time of deluge valve is more, then it can be substantially reduced by installing check valve in branch of release line in the detection network. The check valve flow shall be towards releasing device.
- (3) The pneumatic system must have restricted orifice at air or gas supply point. The restriction nozzle are supplied with LIFECO dry pilot actuation trim.
- (4) UL Listing is valid only when Listed Solenoid Valve provided for electric operation of the deluge valve is retained in the trim. If any other solenoid valve is used, the deluge valve trip time may be quite high or deluge valve may not trip.

DELUGE VALVE MODEL - A SIZE 200/ 150/ 100/ 80/ 50 NB

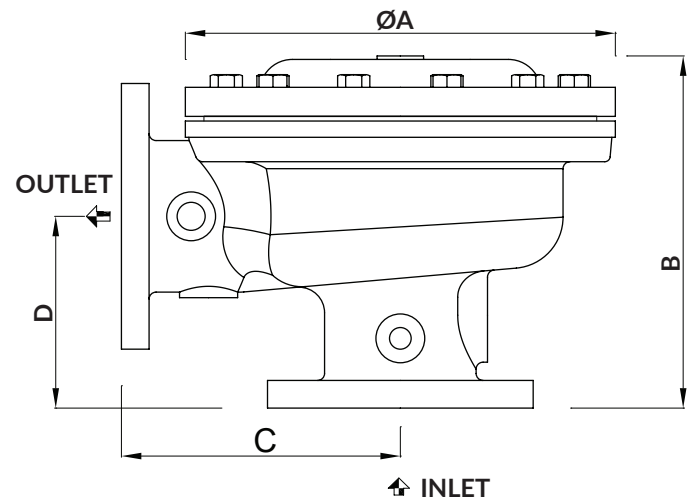

Nominal size of valve	A	B	C	D
200 NB	540	455	330	230
150 NB	464	382	300	200
100 NB	370	304	240	165
80 NB	316	272	210	135
50 NB	316	272	210	135

DIMENSION in millimeters (Approximate)

Deluge Valve Model - A Part List

ITEM	PART NO.					DESCRIPTION	QTY.					MATERIAL DESCRIPTION
	200NB	150NB	100NB	80NB	50NB		200NB	150NB	100NB	80NB	50NB	
1	NA	NA	NA	NA	NA	Housing	1	1	1	1	1	Cast iron
2	2028	2019	2010	2001	2001	Clapper	1	1	1	1	1	Ductile iron *
3	2189	2109	2129	2149	2149	Rubber seat	1	1	1	1	1	EPDM **
4	2029	2020	2011	2002	2002	Rubber clamp	1	1	1	1	1	Ductile iron *
5	9102	9102	9102	9102	9102	Bolt (M10x20)	6	4	4	3	3	Stainless steel
6	2188	2108	2128	2148	2148	Diaphragm	1	1	1	1	1	EPDM **
7	2030	2021	2012	2003	2003	Clamp ring	1	1	1	1	1	Ductile iron *
8	NA	NA	NA	NA	NA	Cover	1	1	1	1	1	Cast iron
9	9003	9003	-	-	-	Bolt (M20x70)	14	14	-	-	-	Carbon steel
	-	-	9009	-	-	Bolt (M16x60)	-	-	10	-	-	Carbon steel
	-	-	-	9008	9008	Bolt (M16x55)	-	-	-	10	12	Carbon steel
10	9105	9105	9105	9105	9105	Bolt (M10x30)	12	12	8	8	8	Stainless steel
11	9023	9023	-	-	-	Bolt (M20x50)	2	2	-	-	-	Carbon steel
	-	-	9007	-	-	Bolt (M16x50)	-	-	2	-	-	Carbon steel
	-	-	-	9006	-	Bolt (M16x45)	-	-	-	2	-	Carbon steel

*Ductile Iron is standard supply, Bronze & Stainless Steel is optional supply.

** EPDM is standard supply with Stainless Steel Seat. Neoprene is optional supply with Stainless Steel & Bronze Seat.

NA - Parts replacement not available.

Note: Seat is not replaceable and is Stainless Steel standard supply, Bronze is optional supply.

Deluge Valve Model - A Size 200/ 150/ 100/ 80/ 50 NB

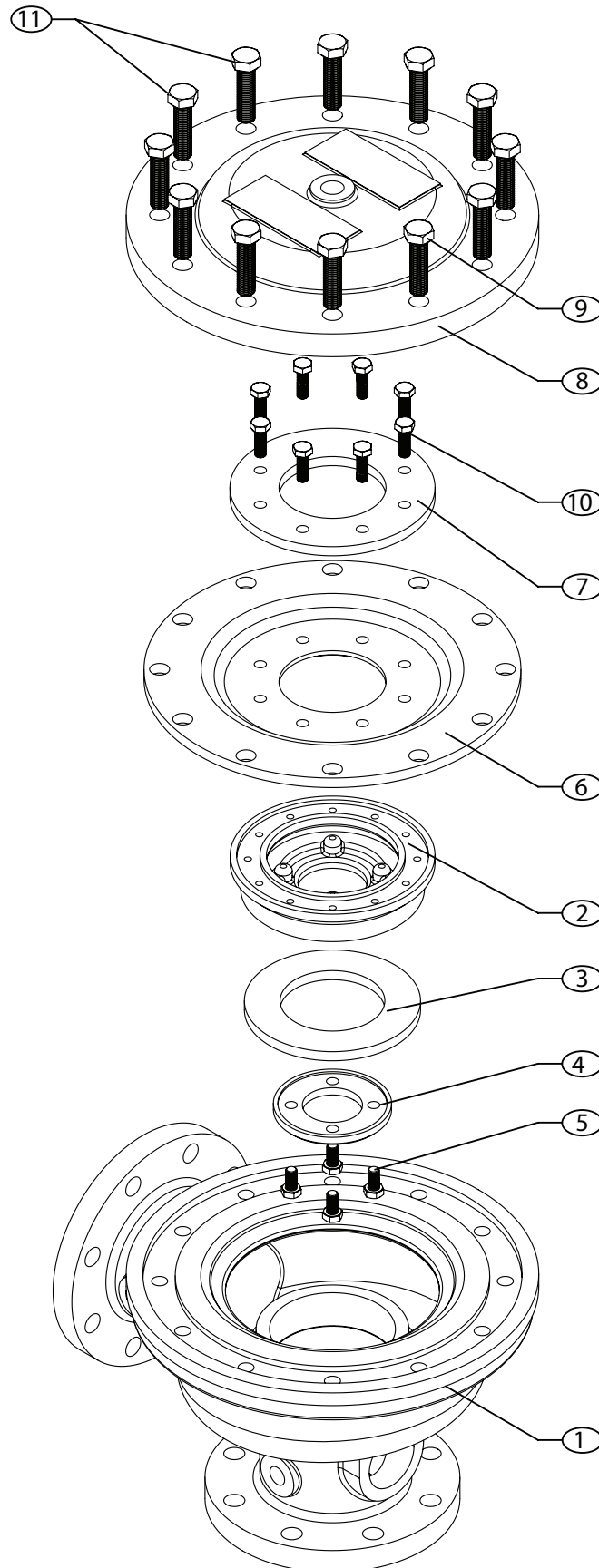

Pneumatic & Electric Release Trim with Test & Alarm Trim for Deluge Valve Model - A

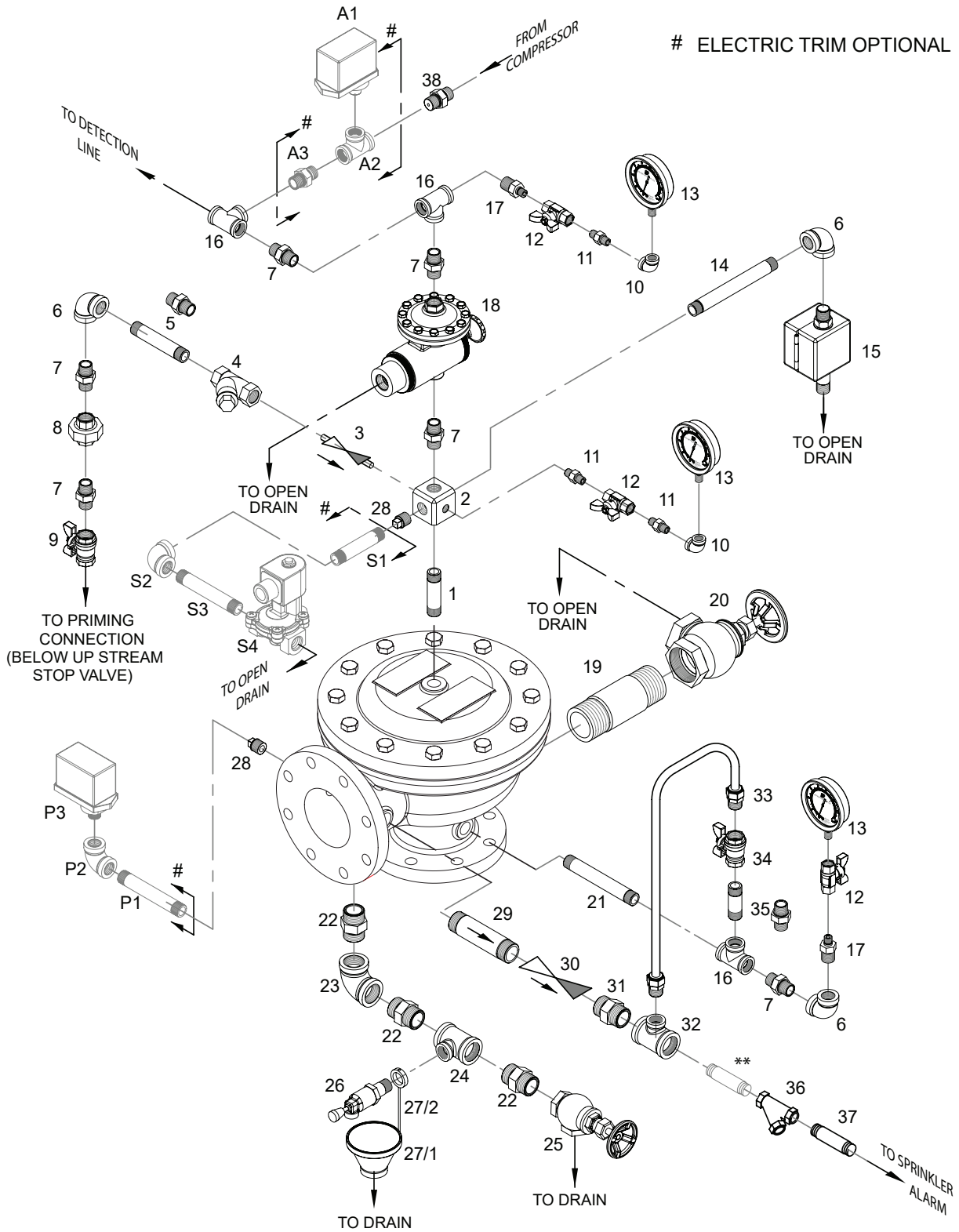

Note: When Electric Trim Is Supplied Then Sl.no.28 Plug Not Required.

** To Suit At Site By Installer

* Supplied Fitted Together

Pneumatic & Electric Release Trim with Test & Alarm Trim for Deluge Valve Model - A

Item No.	Code No.	Description	Size	Quantity per deluge valve size				
				200 NB	150 NB	100 NB	80 NB	50 NB
1	9480	Pipe nipple	1/2" X 80 mm long	1	1	1	1	1
2	6251	6 way manifold	-	1	1	1	1	1
3	6008	NRV with restriction hex nipple	1/2"	1	1	1	1	1
4	9381	"Y" type strainer	1/2"	1	1	1	1	1
5	9416	Pipe nipple	1/2" X110 mm long	1	1	-	-	-
5	8624	Hex nipple	1/2"	-	-	1	1	1
6	8616	Elbow	1/2"	3	3	3	3	3
7	8624	Hex nipple	1/2"	6	6	6	6	6
8	8627	Union	1/2"	1	1	1	1	1
9	9423	Ball valve	1/2"	1	1	1	1	1
10	8357	Elbow	1/4"	2	2	2	2	2
11	8698	Hex nipple	1/4"	3	3	3	3	3
12	9477	Gauge valve	1/4"	3	3	3	3	3
13	9526	Pressure gauge	1/4"	3	3	3	3	3
14	9564	Pipe nipple	1/2" X 300 mm long	1	-	-	-	-
14	9565	Pipe nipple	1/2" X 255 mm long	-	1	-	-	-
14	9403	Pipe nipple	1/2" X 210 mm long	-	-	1	-	-
14	9401	Pipe nipple	1/2" X 180 mm long	-	-	-	1	1
15	-	Emergency release station	-	1	1	1	1	1
16	8619	Tee	1/2"	3	3	3	3	3
17	8631	Reducing hex nipple	1/2" X 1/4"	2	2	2	2	2
18	1436	Positive drain actuator	-	1	1	1	1	1
19	9566	Pipe nipple	2" X 110 mm LONG	1	1	1	-	-
19	9562	Pipe nipple	1-1/4" X 110 mm long	-	-	-	1	1
20	9394	Angle valve	2"	1	1	1	-	-
20	9392	Angle valve	1-1/4"	-	-	-	1	1
21	9414	Pipe nipple	1/2" X 150 mm long	1	1	-	-	-
21	9399	Pipe nipple	1/2" X 130 mm long	-	-	1	1	1
22	8626	Hex nipple	1"	3	3	3	-	-
22	8625	Hex nipple	3/4"	-	-	-	3	3
23	8618	Elbow	1"	1	1	1	-	-
23	8617	Elbow	3/4"	-	-	-	1	1
24	8623	Reducing tee	1" X 1/2" X 1"	1	1	1	-	-
24	8622	Reducing tee	3/4" X 1/2" X 3/4"	-	-	-	1	1
25	9391	Angle valve	1"	1	1	1	-	-
25	9393	Angle valve	3/4"	-	-	-	1	1
26	1911	Drip valve	1/2"	1	1	1	1	1
27/1	6005	Funnel	-	1	1	1	1	1
27/2	6006	Funnel holder	-	1	1	1	1	1
28	8629	Plug	1/2"	2	2	2	2	2
29	9406	Pipe nipple	3/4" X 100 mm long	1	1	1	1	1
30	9421	NRV	3/4"	1	1	1	1	1
31	8625	Hex nipple	3/4"	1	1	1	1	1
32	8622	Reducing tee	3/4" X 1/2" X 3/4"	1	1	1	1	1
33	2198	Copper tube assembly	1/2"	1	-	-	-	-
33	2119	Copper tube assembly	1/2"	-	1	-	-	-
33	2135	Copper tube assembly	1/2"	-	-	1	-	-
33	2157	Copper tube assembly	1/2"	-	-	-	1	1
34	9423	Ball valve	1/2"	1	1	1	1	1
35	8664	Pipe nipple	1/2" X 60 mm long	1	-	-	-	-
35	8624	Hex nipple	1/2"	-	1	1	1	1
36	9382	"Y" type strainer	3/4"	1	1	1	1	1
37	9441	Pipe nipple	3/4" X 80 mm long	1	1	1	1	1
38	1959	Orifice nozzle (air line)	1/2"	1	1	1	1	1
Electric trim for pressure switch (optional)								
P1	9400	Pipe nipple	1/2" X 135 mm long	1	1	1	1	1
P2	8616	Elbow	1/2"	1	1	1	1	1
P3	-	Pressure switch (dv outlet)	1/2" (M)	1	1	1	1	1
A1	-	Pressure switch (air line)	1/2" (M)	1	1	1	1	1
A2	8619	Tee	1/2"	1	1	1	1	1
A3	8624	Hex nipple	1/2"	1	1	1	1	1
Electric trim for solenoid valve (optional)								
S1	9399	Pipe nipple	1/2" X 130 mm long	1	1	1	-	-
S1	9400	Pipe nipple	1/2" X 135 mm long	-	-	-	1	1
S2	8616	Elbow	1/2"	1	1	1	1	1
S3	9401	Pipe nipple	1/2" X 180 mm long	1	1	1	-	-
S3	9400	Pipe nipple	1/2" X 135 mm long	-	-	-	1	1
S4	-	Solenoid valve	1/2" size, two way	1	1	1	1	1

Hydraulic & Electric Release Trim with Test & Alarm Trim for Deluge Valve Model - A

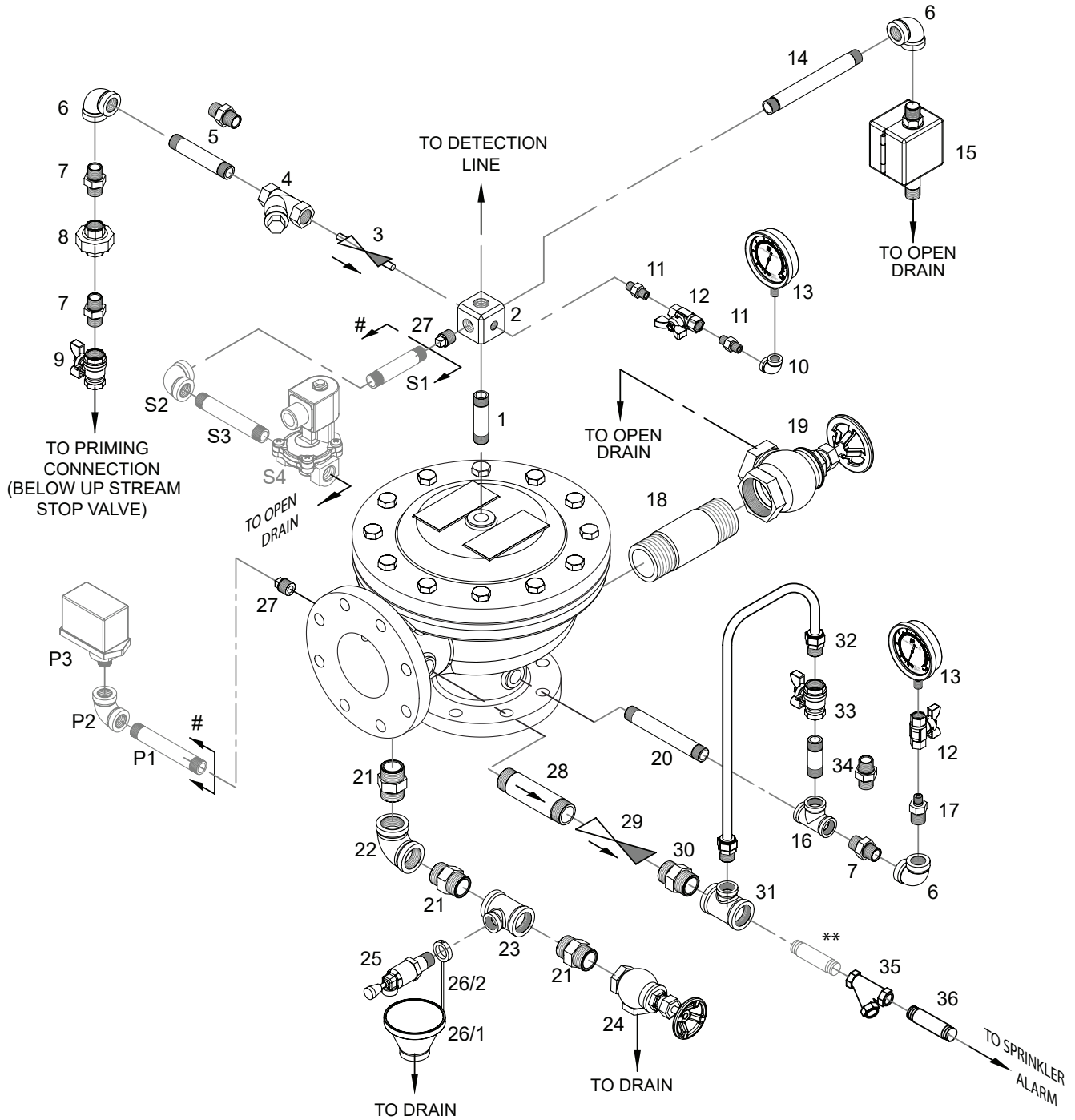

Note: When Electric Trim Is Supplied Then Sl.no.28 Plug Not Required.

** To Suit At Site By Installer

Hydraulic & Electric Release Trim with Test & Alarm Trim for Deluge Valve Model - A

Item No.	Code No.	Description	Size	Quantity per deluge valve size				
				200 NB	150 NB	100 NB	80	50 NB
1	9480	Pipe nipple	1/2" X 80 mm long	1	1	1	1	1
2	6251	6 way manifold	-	1	1	1	1	1
3	6008	NRV with restriction hex nipple	1 1/2"	1	1	1	1	1
4	9381	'Y' type strainer	1/2"	1	1	1	1	1
5	9416	Pipe nipple	1/2" X 110 mm long	1	1	-	-	-
5	8624	Hex nipple	1/2"	-	-	1	1	1
6	8616	Elbow	1/2"	3	3	3	3	3
7	8624	Hex nipple	1/2"	3	3	3	3	3
8	8627	Union	1/2"	1	1	1	1	1
9	9423	Ball valve	1/2"	1	1	1	1	1
10	8357	Elbow	1/4"	1	1	1	1	1
11	8698	Hex nipple	1/4"	2	2	2	2	2
12	9477	Gauge valve	1/4"	2	2	2	2	2
13	9526	Pressure gauge	1/4"	2	2	2	2	2
14	9564	Pipe nipple	1/2" X 300 mm long	1	-	-	-	-
14	9565	Pipe nipple	1/2" X 255 mm long	-	1	-	-	-
14	9403	Pipe nipple	1/2" X 210 mm long	-	-	1	-	-
14	9401	Pipe nipple	1/2" X 180 mm long	-	-	-	1	1
15	-	Emergency release station	-	1	1	1	1	1
16	8619	Tee	1/2"	1	1	1	1	1
17	8631	Reducing hex nipple	1/2" X 1/4"	1	1	1	1	1
18	9566	Pipe nipple	2" X 110 mm long	1	1	1	-	-
18	9562	Pipe nipple	1-1/4" X 110 mm long	-	-	-	1	1
19	9394	Angle valve	2"	1	1	1	-	-
19	9392	Angle valve	1-1/4"	-	-	-	1	1
20	9414	Pipe nipple	1/2" X 150 mm long	1	1	-	-	-
20	9399	Pipe nipple	1/2" X 130 mm long	-	-	1	1	1
21	8626	Hex nipple	1"	3	3	3	-	-
21	8625	Hex nipple	3/4"	-	-	-	3	3
22	8618	Elbow	1"	1	1	1	-	-
22	8617	Elbow	3/4"	-	-	-	1	1
23	8623	Reducing tee	1" X 1/2" X 1"	1	1	1	-	-
23	8622	Reducing tee	3/4" X 1/2" X 3/4"	-	-	-	1	1
24	9391	Angle valve	1"	1	1	1	-	-
24	9393	Angle valve	3/4"	-	-	-	1	1
25	1911	Drip valve	1/2"	1	1	1	1	1
26/1	6005	Funnel	-	1	1	1	1	1
26/2	6006	Funnel holder	-	1	1	1	1	1
27	8629	Plug	1/2"	2	2	2	2	2
28	9406	Pipe nipple	3/4" X 100 mm long	1	1	1	1	1
29	9421	NRV	3/4"	1	1	1	1	1
30	8625	Hex nipple	3/4"	1	1	1	1	1
31	8622	Reducing tee	3/4" X 1/2" X 3/4"	1	1	1	1	1
32	2198	Copper tube assembly	1/2"	1	-	-	-	-
32	2119	Copper tube assembly	1/2"	-	1	-	-	-
32	2135	Copper tube assembly	1/2"	-	-	1	-	-
32	2157	Copper tube assembly	1/2"	-	-	-	1	1
33	9423	Ball valve	1/2"	1	1	1	1	1
34	8664	Pipe nipple	1/2" X 60 mm long	1	-	-	-	-
34	8624	Hex nipple	1/2"	-	1	1	1	1
35	9382	"Y" type strainer	3/4"	1	1	1	1	1
36	9441	Pipe nipple	3/4" X 80 mm long	1	1	1	1	1
Electric trim for pressure switch (optional)								
P1	9400	Pipe nipple	1/2" X 135 mm long	1	1	1	1	1
P2	8616	Elbow	1/2"	1	1	1	1	1
P3	-	Pressure switch (dv outlet)	1/2" (M)	1	1	1	1	1
Electric trim for solenoid valve (optional)								
S1	9399	Pipe nipple	1/2" X 130 mm long	1	1	1	-	-
S1	9400	Pipe nipple	1/2" X 135 mm long	-	-	-	1	1
S2	8616	Elbow	1/2"	1	1	1	1	1
S3	9401	Pipe nipple	1/2" X 180 mm long	1	1	1	-	-
S3	9400	Pipe nipple	1/2" X 135 mm long	-	-	-	1	1
S4	-	Solenoid valve	1/2" Size, Two Way	1	1	1	1	1



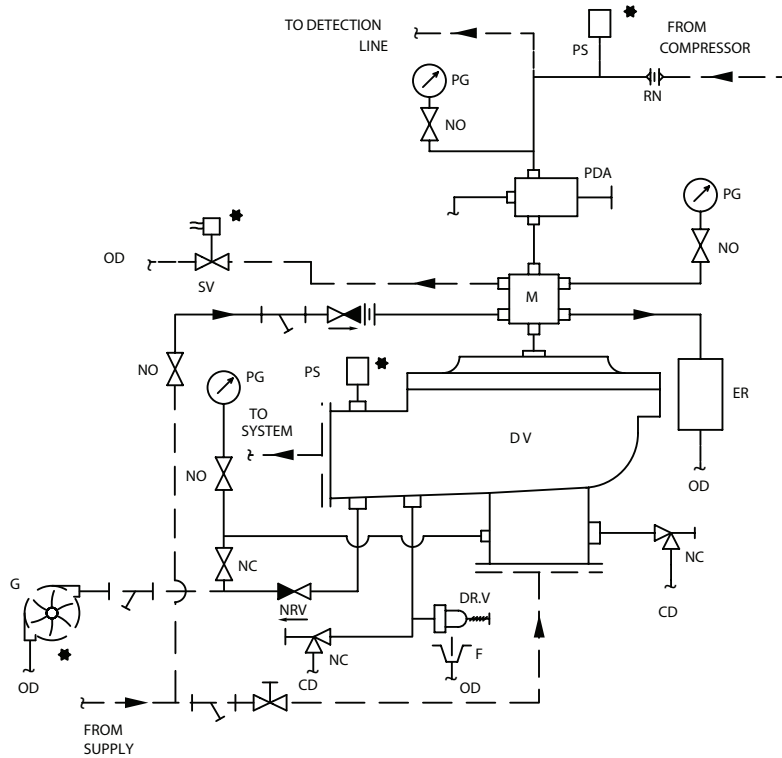



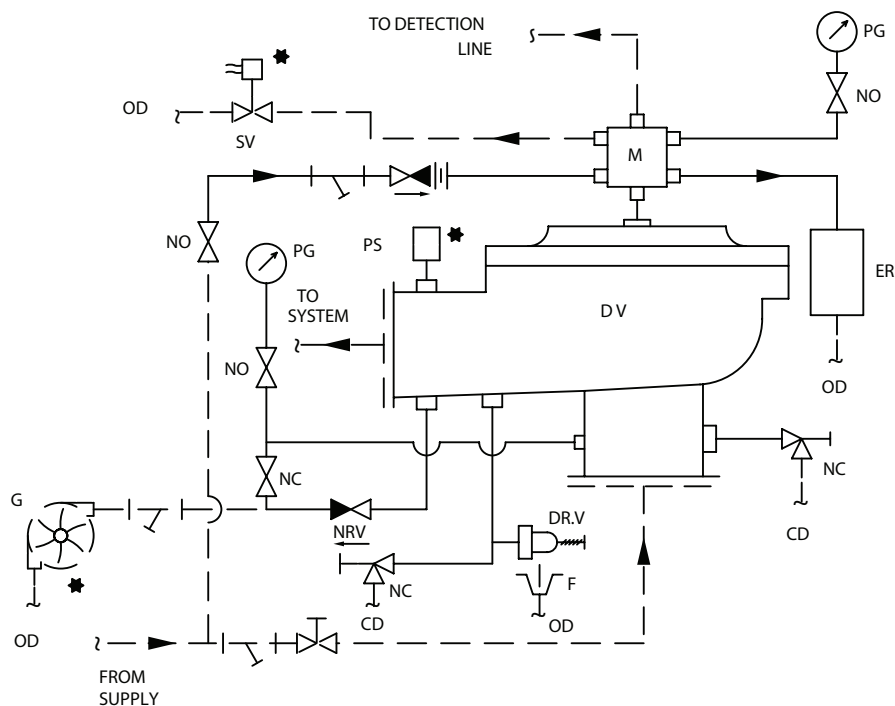

















Electric & Pneumatic Release Trim - Schematic Deluge Valve Model - A Size 200 / 150 / 100 / 80 / 50 NB



Electric & Hydraulic Release Trim - Schematic Deluge Valve Model - A Size 200 / 150 / 100 / 80 / 50 NB



ABBREVIATION & SYMBOLS

	Valve		Angle Valve		Pressure Switch		DR.V Drip Valve
	NR Non Return Valve		DV Deluge Valve		Stop Valve		F Funnel
	ER Emergency Release Box		Optional		CD Common Drain		--- By User
	M Six Way Manifold		G Sprinkler Alarm		NRV with Restriction Hex Nipple		OD Open Drain
	RN Restriction Nozzle		PG Pressure Switch		SV Solenoid Valve		Strainer
	PDA Positive Drain Actuator		NO Normally Open		NC Normally Closed		CV Check Valve

Pneumatic and Electric Release Trim

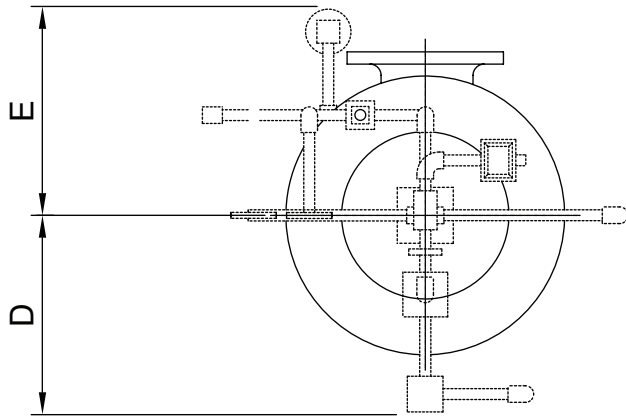

Hydraulic and Electric Release Trim

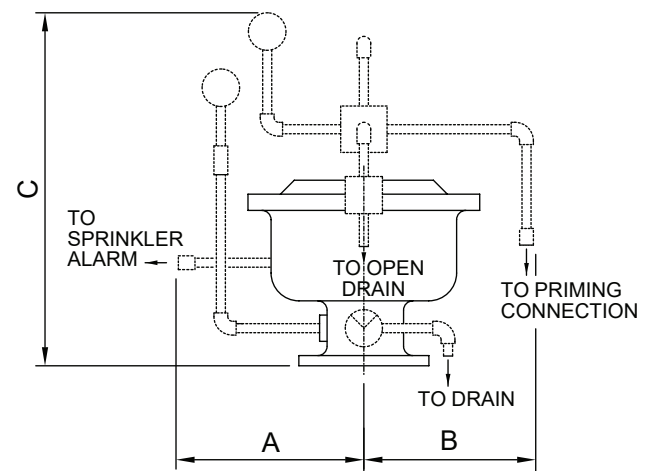
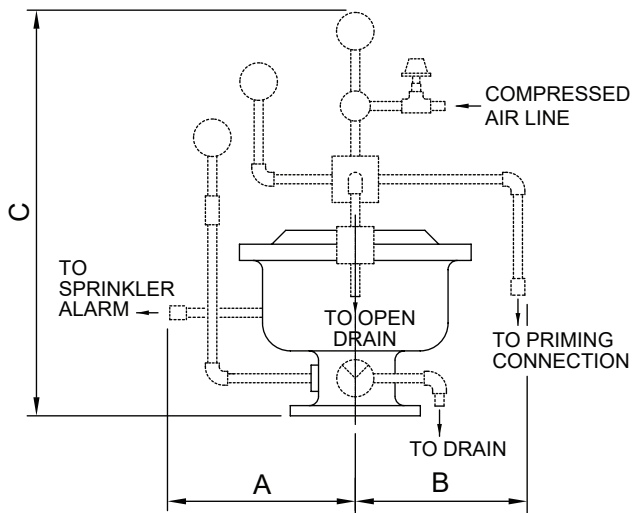
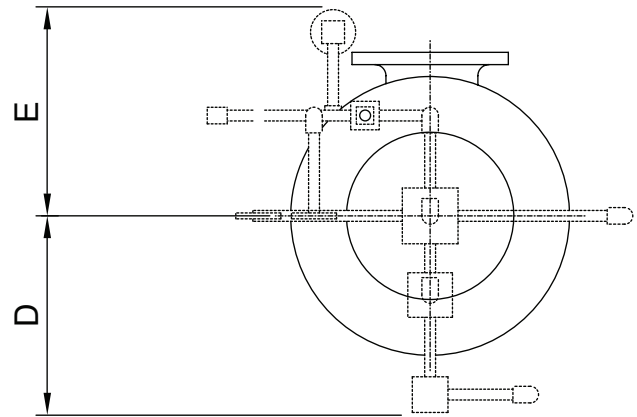

INSTALLATION MEASUREMENT IN MM. (APPROXIMATE)

Size	200NB	150NB	100NB	80NB	50NB
A	390	370	370	350	350
B	525	500	450	450	450
C	1050	1025	950	930	930
D	510	500	450	450	450
E	500	480	420	410	410

INSTALLATION MEASUREMENT IN MM. (APPROXIMATE)

Size	200NB	150NB	100NB	80NB	50NB
A	390	370	370	350	350
B	525	500	450	450	450
C	875	800	750	700	700
D	510	500	450	450	450
E	500	480	420	410	410

Wet Pilot Sprinkler Height Limitation of 200 NB

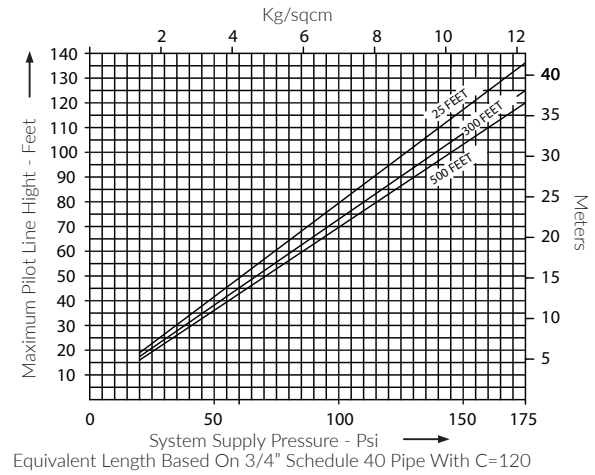
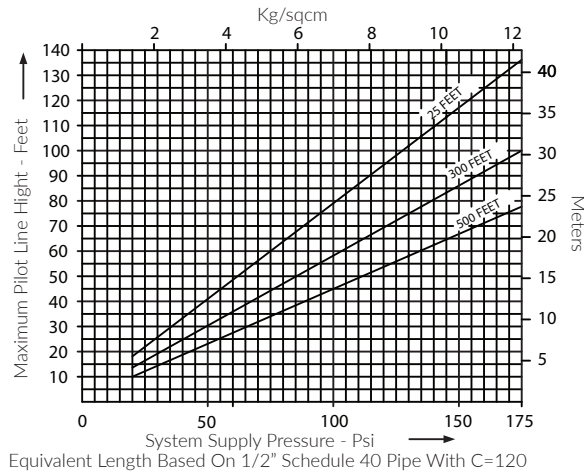

Wet Pilot Sprinkler Height Limitation of 150 NB

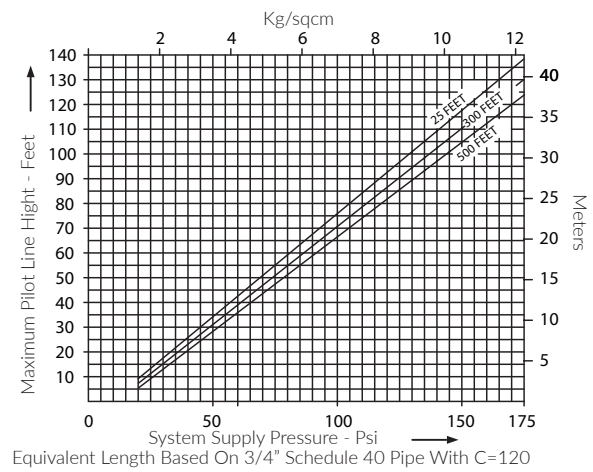
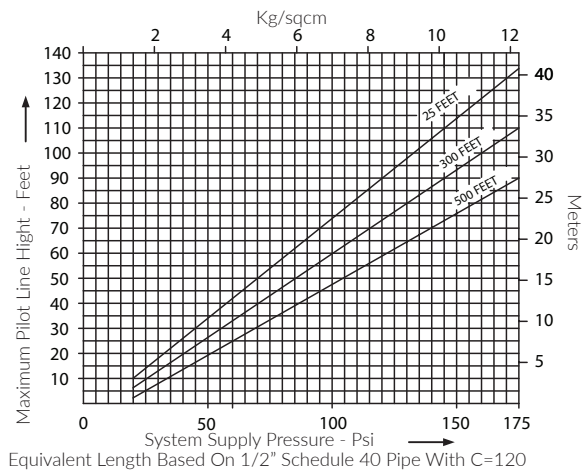

Wet Pilot Sprinkler Height Limitation of 100 NB

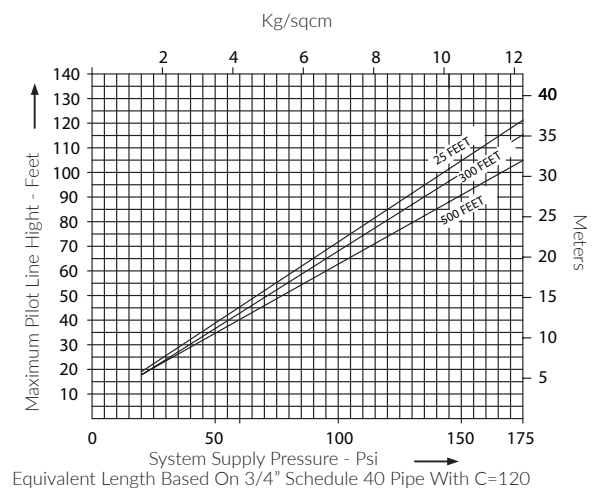
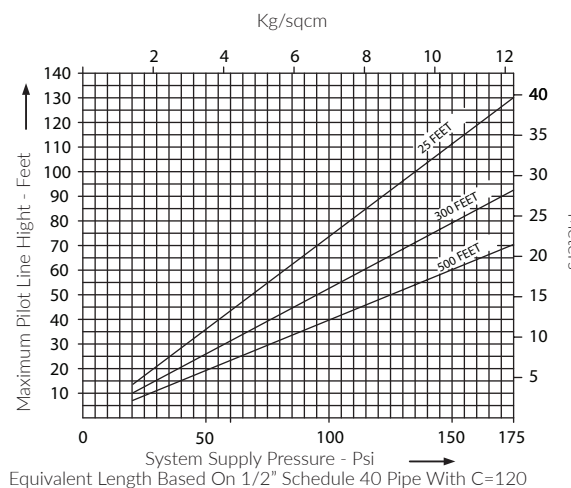

Wet Pilot Sprinkler Height Limitation of 80 NB

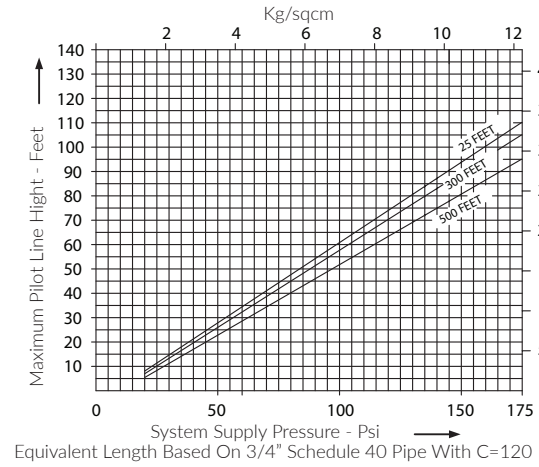
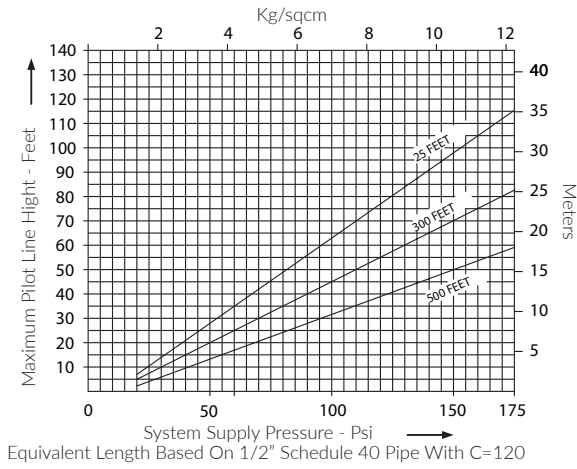

Wet Pilot Sprinkler Height Limitation of 50 NB

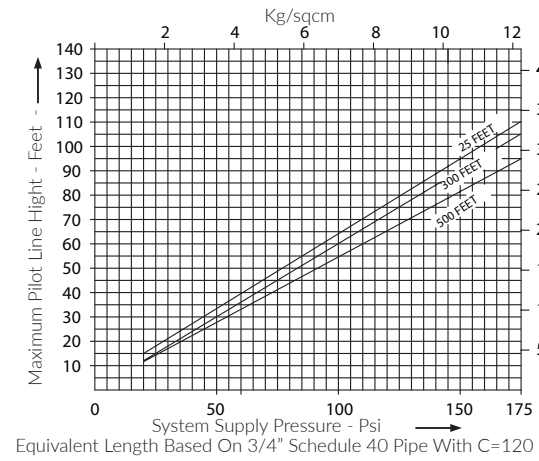
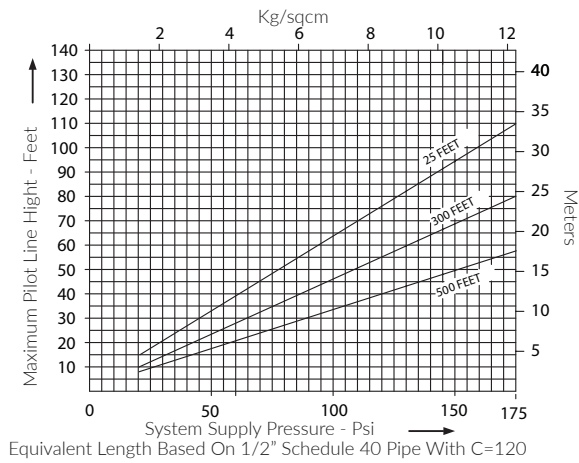

Nominal Pressure Loss Vs Flow - Deluge Valve Model A

