

## Schematic Drawing

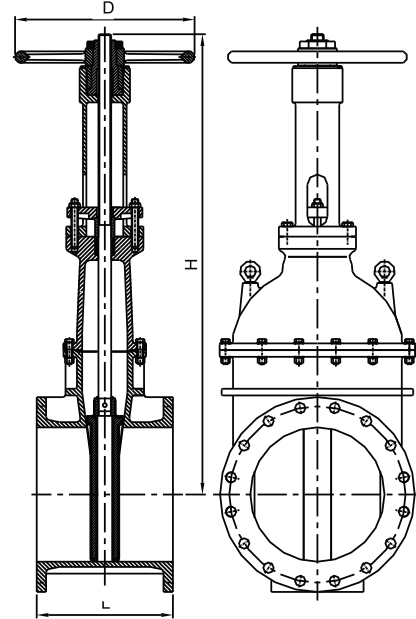

## Features

- Complies with AWWA C515 Standard
- Heavy duty handwheel and attachment nut
- High quality graphite stem seal
- NPT plug on body
- Flanged to ANSI B16. 1 Class125 (Other flange types available upon request)
- 250PSI Working pressure
- -10°C to 82°C Working temperature
- Corrosion protection - Fusion bonded epoxy coated interior and exterior to AWWA C550 standard
- *NPT plug - Optional*

## Material Specification

Part Name	Material	ASTM Spec.
Body	Ductile iron	A536 65-45-12
Wedge	Ductile iron	EPDM Encapsulated
Wedge nut	Bronze	B62 C83600
Stem	Stainless steel	AISI 420
Bonnet	Ductile iron	A536 65-45-12
Gasket	Rubber	EPDM
Packing	Graphite	Commercial
Gland	Ductile iron	A536 65-45-12
Yoke Nut	Bronze	B62 C83600
Hand wheel	Ductile iron	A536 65-45-12
Hand wheel Nut	Ductile iron	A536 65-45-12
NPT Plug	Malleable iron	Commercial
Gland Bolt	Stainless steel	AISI 316
Gland Bolt	Carbon steel	A307 B

## Notes:

-Design and material are subject to change without notice.

## Dimensions (mm/inch)

Size	350/14"		400/16"		450/18"	
	mm	inch	mm	inch	mm	inch
L	381	15	406	16	432	17
H (Open)	1574	61.97	1786	70.31	2020	79.53
H (Close)	1224	48.19	1386	54.57	1570	61.81
D	445	17.5	535	21	610	24