

Description

Pressure reducing device angle valve 175 lb. rated adjustable restriction of residual pressure up to 175 lb. locking pin device restricts full opening of valve by untrained personnel, pin may be removed by firefighters to allow full opening valve.

Standard equipment : Female NPT inlet and outlet forged brass valve red hand wheel

Chrome Plated Finish is Available Upon Request

Model	Size	A	B	C	D	E
LF-RV-AH15	1½ x 1½	100	48	62	123	145
LF-RV-AH25	2½ x 2½	127	67	83	165	206

Description

Pressure reducing device angle valve 175 lb. rated adjustable restriction of residual pressure up to 175 lb. locking pin device restricts full opening of valve by untrained personnel, pin may be removed by firefighters to allow full opening valve.

Standard equipment : Female NPT inlet x male hose thread outlet forged brass valve red hand wheel

Chrome Plated Finish is Available Upon Request

Model	Size	A	B	C	D	E
LF-RV-AH20	1½ x 1½	100	48	58	123	145
LF-RV-AH30	2½ x 2½	127	67	77	165	206

Material & Technical Specification

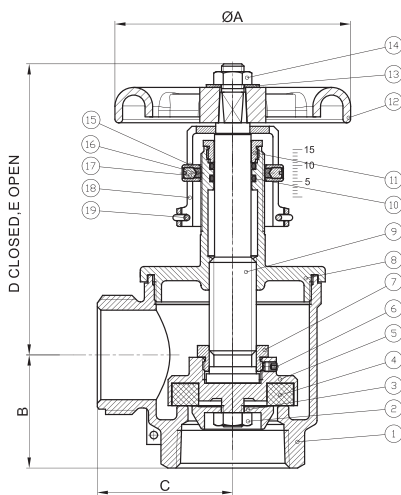

No.	Description	Material
1	Body	ASTM B283 C37700
2	Nut	ASTM B283 C37700
3	Washer	304
4	Seat Seal	EPDM (A70)
5	Holder	ASTM B283 C37700
6	Set Screw	304
7	Lock Nut	ASTM B283 C37700
8	Bonnet	ASTM B283 C37700
9	Stem	ASTM B283 C37700
10	O-ring	EPDM (A70)
11	Lock Nut	ASTM B283 C37700
12	Handle Wheel	ZL102
13	Wheel Washer	304
14	Wheel Nut	ASTM B283 C37700
15	Collar	ASTM B283 C37700
16	Washer	PA6
17	Set Screw	304
18	Set Numbers	ASTM B283 C37700
19	Wire	304